

1 TOP VIEW
SCALE: 1" = 1'-0"

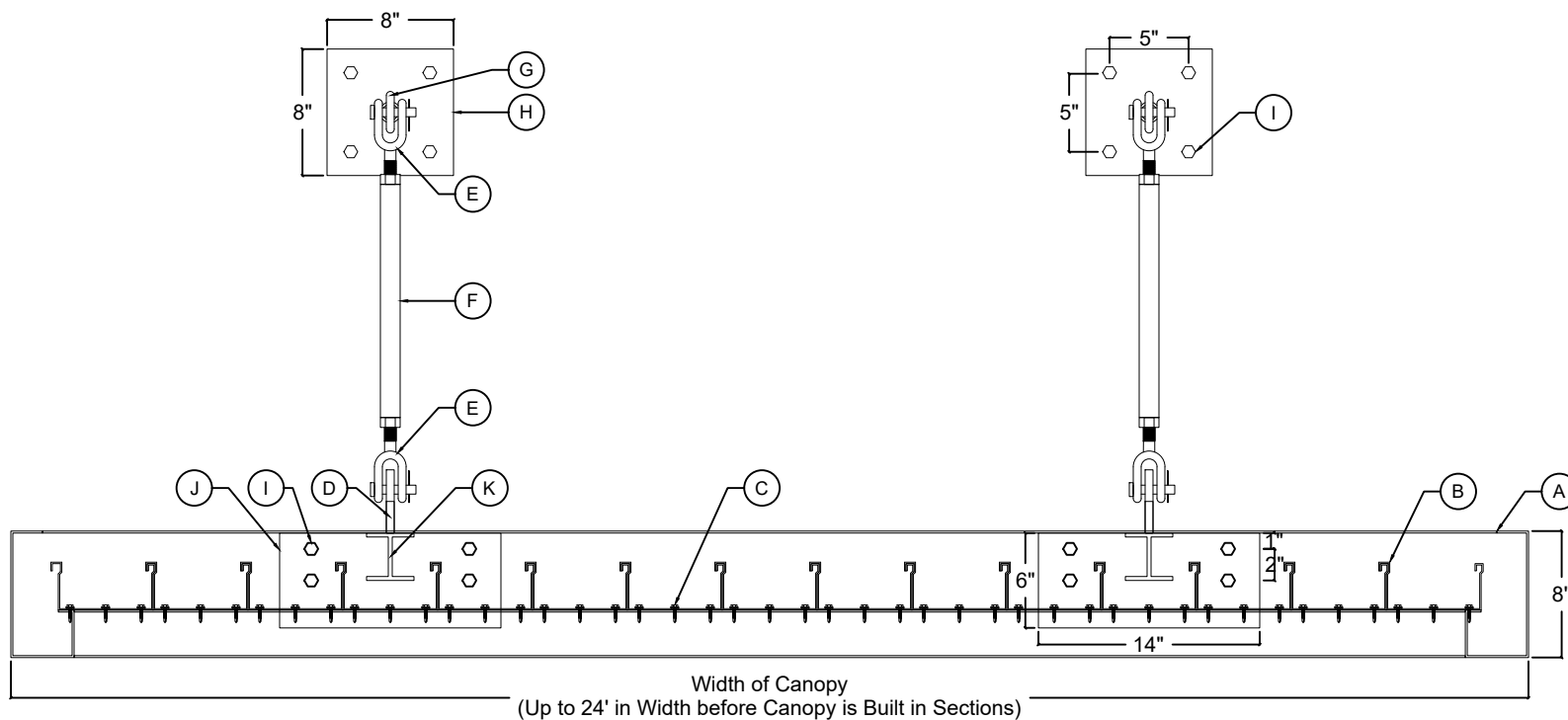

2 TRANSVERSE VIEW
SCALE: 1" = 1'-0"

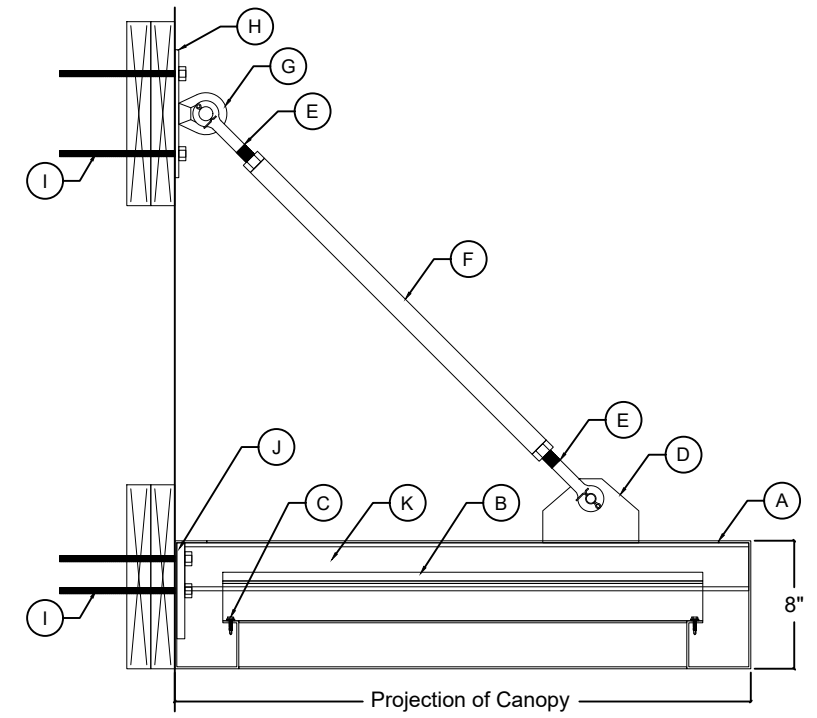

3 PROFILE
SCALE: 1" = 1'-0"

CANOPY FABRICATION DETAILS	
PART LABEL	DESCRIPTION
A	8" (h) x 4" (w) x 1/8" (thick) ALUMINUM FLAT-FACE GUTTER EXTRUSION
B	3" (h) x 6" (w) x 1/8" (thick) EXTRUDED ALUMINUM INDIVIDUAL SELF-MATING DECK-PANS / TOP-GUTTERS
C	#10 X 1" HEX-HEAD TEK-SCREWS WITH RUBBER WASHERS
D	4" (h) x 6" (w) x 1/2" (thick) ALUMINUM PLATE SUPPORT KNUCKLES
E	1/2" (thick) STEEL CLEVIS 1/2" LOCKING PIN PRE-WELDED 3/4" (thick) THREADED-ROD
F	1-1/4" SCH40 PIPE WITH PRE-WELDED NUTS
G	1/2" (thick) ALUMINUM "D-RING" EYENUT
H	8" x 8" x 1/4" (thick) ALUMINUM TOP-MOUNTING "ESCUTCHEON" PLATES
I	3/8" LAG BOLTS
J	6" (h) x 14" (w) x 1/2" (thick) ALUMINUM BOTTOM MOUNTING PLATES (WELDED TO I-BEAM SUPPORTS)
K	3" x 3" ALUMINUM I-BEAM SUPPORTS (WELDED TO MOUNTING PLATES & CANOPY FRAME)

**STANDARD ARCHITECTURAL CANOPY | 8" (h) x 4" (w) GUTTER EXTRUSION
TURNBUCKLE-SUPPORTS MOUNTING SYSTEM**

