

**1 TOP VIEW**  
SCALE: 1" = 1'-0"

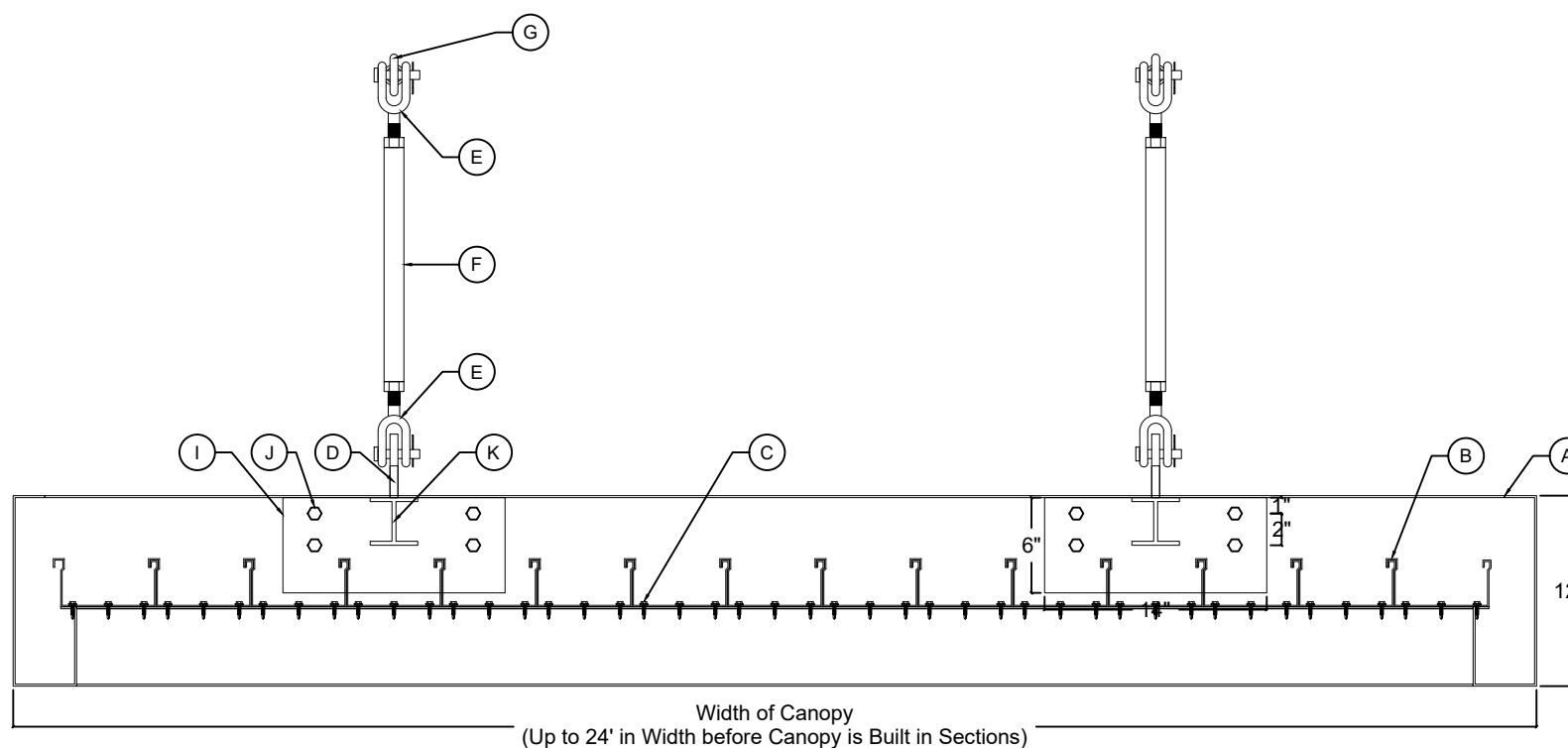

**2 TRANSVERSE VIEW**  
SCALE: 1" = 1'-0"

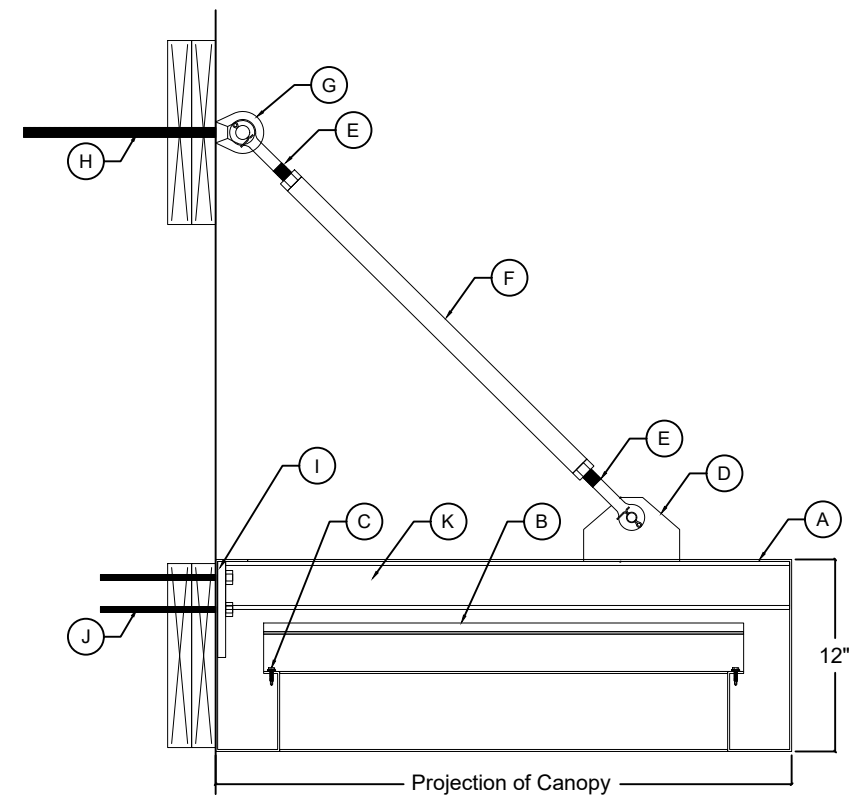

**3 PROFILE**  
SCALE: 1" = 1'-0"

### CANOPY FABRICATION DETAILS

PART LABEL	DESCRIPTION
A	12" (h) x 4" (w) x 1/8" (thick) ALUMINUM FLAT-FACE GUTTER EXTRUSION
B	3" (h) x 6" (w) x 1/8" (thick) EXTRUDED ALUMINUM INDIVIDUAL SELF-MATING DECK-PANS / TOP-GUTTERS
C	#10 X 1" HEX-HEAD TEK-SCREWS WITH RUBBER WASHERS
D	4" (h) x 6" (w) x 1/2" (thick) ALUMINUM PLATE SUPPORT KNUCKLES
E	1/2" (thick) STEEL CLEVIS   1/2" LOCKING PIN   PRE-WELDED 3/4" (thick) THREADED-ROD
F	1-1/4" SCH40 PIPE WITH PRE-WELDED NUTS
G	1/2" (thick) ALUMINUM "D-RING" EYENUT
H	5/8" THREADED-ROD
I	6" (h) x 14" (w) x 1/2" (thick) ALUMINUM BOTTOM MOUNTING PLATES (WELDED TO I-BEAM SUPPORTS)
J	3/8" LAG BOLTS
K	3" x 3" ALUMINUM I-BEAM SUPPORTS (WELDED TO MOUNTING PLATES & CANOPY FRAME)

**STANDARD ARCHITECTURAL CANOPY | 12" (h) x 4" (w) GUTTER EXTRUSION**  
TURNBUCKLE-SUPPORTS MOUNTING SYSTEM

